



Main

Range compatibility	Lexium 28
Device short name	BCH2
Product or component type	Servo motor

Complementary

Maximum mechanical speed	5000 rpm
[Us] rated supply voltage	220 V 110 V
Network number of phases	Single phase Three phase
Continuous stall current	0.54 A
Continuous stall torque	0.16 N.M for LXM28... at 0.64 A, 220 V, single phase 0.16 N.M for LXM28... at 0.64 A, 220 V, three phase 0.16 N.m for LXM28... at 1.2 A, 110 V, single phase
Continuous power	50 W
Peak stall torque	0.48 N.M for LXM28... at 0.64 A, 220 V, single phase 0.48 N.M for LXM28... at 0.64 A, 220 V, three phase 0.48 N.m for LXM28... at 1.2 A, 110 V, single phase
Nominal output power	50 W for LXM28... at 0.64 A, 220 V, single phase 50 W for LXM28... at 0.64 A, 220 V, three phase 50 W for LXM28... at 1.2 A, 110 V, single phase
Nominal torque	0.16 N.M for LXM28... at 0.64 A, 220 V, single phase 0.16 N.M for LXM28... at 0.64 A, 220 V, three phase 0.16 N.m for LXM28... at 1.2 A, 110 V, single phase
Nominal speed	3000 rpm for LXM28... at 0.64 A, 220 V, single phase 3000 rpm for LXM28... at 0.64 A, 220 V, three phase 3000 rpm for LXM28... at 1.2 A, 110 V, single phase
Maximum current Irms	1.77 A for LXM28... at 0.05 kW, 220 V 1.77 A for LXM28... at 0.05 kW, 110 V
Maximum permanent current	0.59 A
Product compatibility	LXM28... servo drive motor at 0.05 kW, 220 V, single phase LXM28... servo drive motor at 0.05 kW, 220 V, three phase LXM28... servo drive motor at 0.05 kW, 110 V, single phase
Shaft end	Smooth shaft
Shaft diameter	8 mm
Shaft length	25 mm
Feedback type	20 bits single turn absolute encoder
Holding brake	Without
Mounting support	Asian standard flange
Motor flange size	40 mm
Electrical connection	Free lead
Torque constant	0.3 N.m/A at 20 °C
Back emf constant	18 V/krpm at 20 °C

Rotor inertia	0.054 kg.cm ²
Stator resistance	31 Ohm at 20 °C
Stator inductance	24.7 mH at 20 °C
Stator electrical time constant	0.8 ms at 20 °C
Maximum radial force Fr	85 N at 3000 rpm
Maximum axial force Fa	40 N
Brake pull-in power	4.35 W
Type of cooling	Natural convection
Length	82 mm
Number of motor stacks	1
Centring collar diameter	30 mm
Centring collar depth	3 mm
Number of mounting holes	4
Mounting holes diameter	4.5 mm
Circle diameter of the mounting holes	46 mm
Distance shaft shoulder-flange	3 mm
Net weight	0.4 kg

Environment

IP degree of protection	IP50 IM V3 IP65 IM B5, IM V1
Ambient air temperature for operation	-20...40 °C

Packing Units

Unit Type of Package 1	PCE
Number of Units in Package 1	1
Package 1 Height	8.0 cm
Package 1 Width	13.0 cm
Package 1 Length	24.0 cm
Package 1 Weight	643.0 g

Offer Sustainability

Sustainable offer status	Green Premium product
REACH Regulation	REACH Declaration
REACH free of SVHC	Yes
EU RoHS Directive	Pro-active compliance (Product out of EU RoHS legal scope)
Mercury free	Yes
China RoHS Regulation	China RoHS Declaration
RoHS exemption information	Yes
Environmental Disclosure	Product Environmental Profile
Circularity Profile	End Of Life Information
WEEE	The product must be disposed on European Union markets following specific waste collection and never end up in rubbish bins
PVC free	Yes

Dimensions

Dimensions of Motor

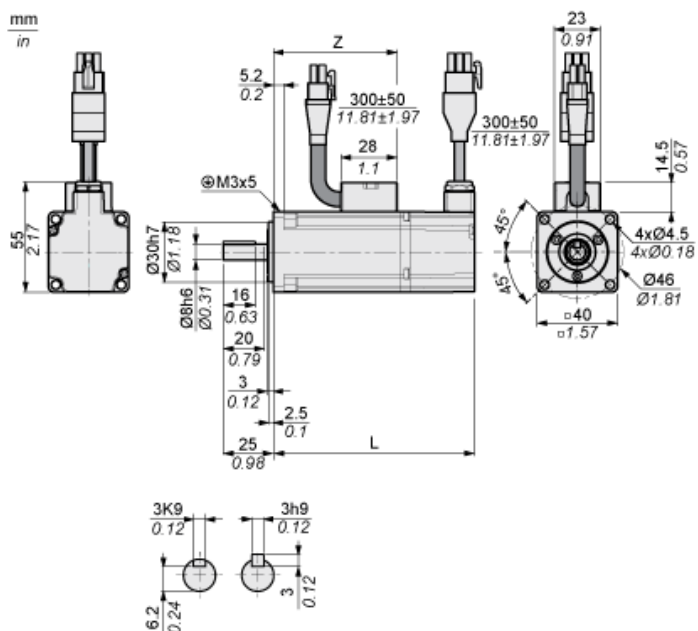

	mm	in.
L (without holding brake)	82	3.23
L (with holding brake)	112	4.41
Z	43.5	1.71

Torque/Speed Curves with 230 V Single/Three Phase Supply Voltage

Servo Motor Without Shaft Sealing Ring and LXM28AUA5●●● Servo Drive

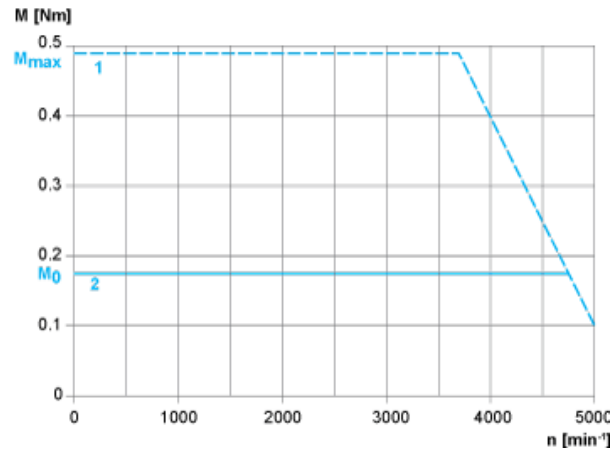

- 1 : Peak torque
- 2 : Continuous torque

Torque/Speed Curves with 230 V Single/Three Phase Supply Voltage

Servo Motor with shaft sealing ring and LXM28AUA5●●● Servo Drive

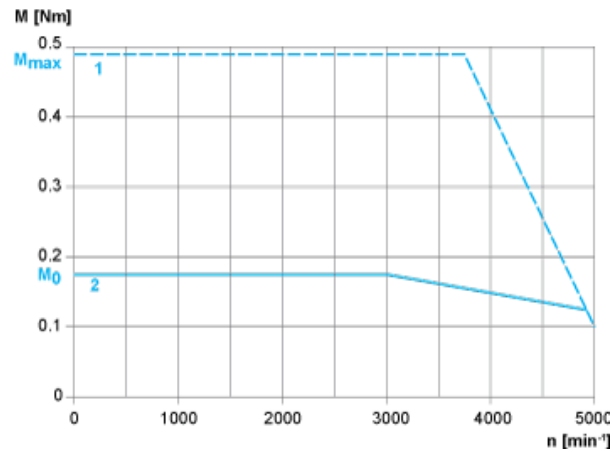

- 1 : Peak torque
- 2 : Continuous torque