



Main

Range compatibility	Lexium 32i
Device short name	BMI
Product or component type	Servo motor with power stage

Complementary

Maximum mechanical speed	8000 rpm
[Us] rated supply voltage	208...480 V - 15...10 %
Supply voltage limits	208...480 V
Network number of phases	Three phase
Supply frequency	50/60 Hz - 5...5 %
Network frequency limits	47.5...63 Hz
EMC filter	Integrated
Continuous output current	2 A at 8 kHz
Output current 3s peak	6 A at 400 V for 3 s
Continuous stall current	2 A
Continuous stall torque	3.4 N.m at 208...480 V three phase
Peak stall torque	8.6 N.M at 208 V three phase 8.6 N.M at 400 V three phase 8.6 N.m at 480 V three phase
Nominal output power	900 W at 400 V three phase 900 W at 480 V three phase 450 W at 208 V three phase
Nominal torque	2.9 N.M at 208 V three phase 2.7 N.M at 400 V three phase 2.3 N.m at 480 V three phase
Nominal speed	3300 rpm at 400 V three phase 1600 rpm at 208 V three phase 3900 rpm at 480 V three phase
Maximum current Irms	12.5 A at 400 V, three phase 12.5 A at 480 V, three phase 12.5 A at 208 V, three phase
Product compatibility	Drive control unit LXM32i CANopen Drive control unit LXM32i EtherCAT
Shaft end	Untapped
Second shaft	Without second shaft end
Shaft diameter	14 mm
Shaft length	30 mm
Feedback type	Absolute multiturn SinCos Hiperface
Speed feedback resolution	32768 points/turn x 4096 turns
Holding brake	With
Holding torque	3 N.m holding brake

The information provided in this documentation contains general descriptions and/or technical characteristics of the performance of the products contained herein. This documentation is not intended as a substitute for and is not to be used for determining suitability or reliability of these products for specific user applications. It is the duty of any such user or integrator to perform the appropriate and complete risk analysis, evaluation and testing of the products with respect to the relevant specific application or use thereof. Neither Schneider Electric Industries SAS nor any of its affiliates or subsidiaries shall be responsible or liable for misuse of the information contained herein.

Mounting support	International standard flange
Motor flange size	70 mm
Electrical connection	Printed circuit board connector
Torque constant	1.41 N.m/A at 20 °C
Back emf constant	95.39 V/krpm at 20 °C
Number of motor poles	10
Rotor inertia	1.78 kg.cm ²
Stator resistance	7.99 Ohm at 20 °C
Stator inductance	25.6 mH at 20 °C
Stator electrical time constant	3.2 ms at 20 °C
Maximum radial force Fr	730 N at 1000 rpm 580 N at 2000 rpm 510 N at 3000 rpm 460 N at 4000 rpm 430 N at 5000 rpm 400 N at 6000 rpm
Maximum axial force Fa	0.2 x Fr
Brake pull-in power	5 W
Type of cooling	Natural convection
Length	339 mm
Number of motor stacks	3
Centring collar diameter	60 mm
Centring collar depth	2.5 mm
Number of mounting holes	4
Mounting holes diameter	5.5 mm
Circle diameter of the mounting holes	75...82 mm
Distance shaft shoulder-flange	2.5 mm

Environment

IP degree of protection	Shaft: IP54 Housing: IP65
-------------------------	------------------------------

Packing Units

Unit Type of Package 1	PCE
Number of Units in Package 1	1
Package 1 Height	25.8 cm
Package 1 Width	20.0 cm
Package 1 Length	59.0 cm
Package 1 Weight	6.5 kg
Unit Type of Package 2	P06
Number of Units in Package 2	8
Package 2 Height	77.0 cm
Package 2 Width	80.0 cm
Package 2 Length	60.0 cm
Package 2 Weight	60.5 kg

Offer Sustainability

Sustainable offer status	Green Premium product
REACH Regulation	 REACH Declaration
EU RoHS Directive	Pro-active compliance (Product out of EU RoHS legal scope)
Mercury free	Yes
China RoHS Regulation	 China RoHS Declaration
RoHS exemption information	 Yes
Environmental Disclosure	 Product Environmental Profile
Circularity Profile	 End Of Life Information

WEEE	The product must be disposed on European Union markets following specific waste collection and never end up in rubbish bins
PVC free	Yes
Contractual warranty	
Warranty	18 months

External Dimensions

With Standard Braking Resistor

Mounting type A

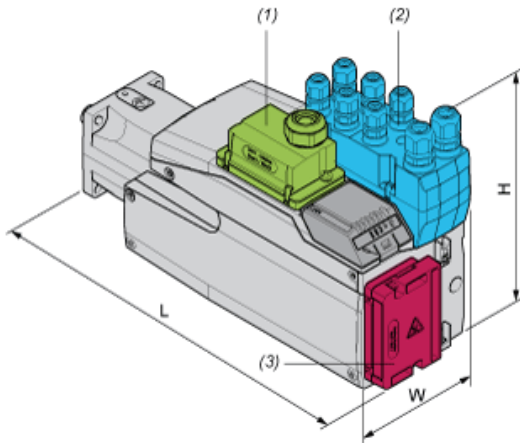

- (1) Module for supply voltage
- (2) I/O module
- (3) Standard braking resistor

Dimensions in mm

W	H	L
99	187	360

Dimensions in in.

W	H	L
3,90	7,36	14,17

Mounting type B



- (1) Module for supply voltage
- (2) I/O module
- (3) Standard braking resistor

Dimensions in mm

W	H	L
99	138,5	409

Dimensions in in.

W	H	L
3,90	5,45	16,1

With External Braking Resistor

Mounting type C



- (1) Module for supply voltage
- (2) I/O module
- (4) External braking resistor

Dimensions in mm

W	H	L
99	187	372

Dimensions in in.

W	H	L
3,90	7,36	14,65

Mounting type D



- (1) Module for supply voltage
- (2) I/O module
- (4) External braking resistor

Dimensions in mm

W	H	L
99	160	409

Dimensions in in.

W	H	L
3,90	6,3	16,1

Mounting type E



- (1) Module for supply voltage
- (2) I/O module
- (4) External braking resistor

Dimensions in mm

W	H	L
99	187	399

Dimensions in in.

W	H	L
3,90	7,36	15,71

Mounting type F



- (1) Module for supply voltage
- (2) I/O module
- (4) External braking resistor

Dimensions in mm

W	H	L
99	180	409

Dimensions in in.

W	H	L
3,90	7,09	16,1

Performance Curves

Torque/Speed Curves with 208 V Three Phases Supply Voltage



- (X) Speed (rpm)
- (Y) Torque (N.m)
- (1) Motor peak
- (2) Drive peak
- (3) Drive cont
- (4) Motor cont
- (5) Operating point

		Power	At Speed	With Torque
max. Peak Power	■	1138 W	1360 rpm	7.99 N.m
max Cont. Power (Drive)	●	564 W	1840 rpm	2.93 N.m

Performance Curves

Torque/Speed Curves with 400 V Three Phases Supply Voltage



- (X) Speed (rpm)
- (Y) Torque (N.m)
- (1) Motor peak
- (2) Drive peak
- (3) Drive cont
- (4) Motor cont
- (5) Operating point

		Power	At Speed	With Torque
max. Peak Power	■	2390 W	2960 rpm	7.71 N.m
max Cont. Power (Drive)	●	895 W	3760 rpm	2.27 N.m

Torque/Speed Curves with 480 V Three Phases Supply Voltage

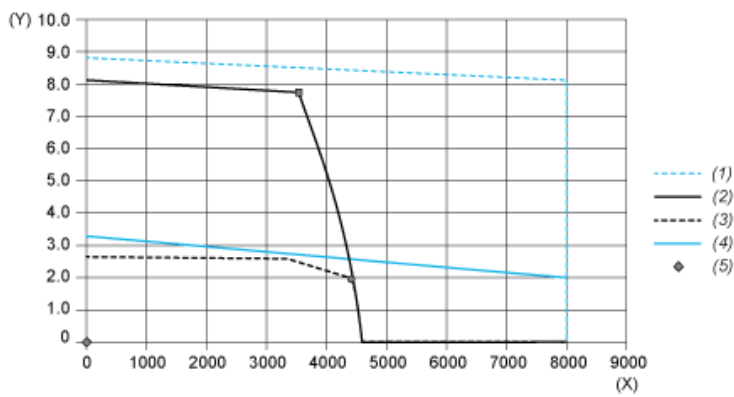

- (X) Speed (rpm)
- (Y) Torque (N.m)
- (1) Motor peak
- (2) Drive peak
- (3) Drive cont
- (4) Motor cont
- (5) Operating point

		Power	At Speed	With Torque
max. Peak Power	■	2915 W	3600 rpm	7.73 N.m
max Cont. Power (Drive)	●	945 W	4560 rpm	1.98 N.m