



## Main

Range of product	Lexium integrated drive
Product or component type	Motion integrated drive
Device short name	ILA
Motor type	AC synchronous servo motor
Number of motor poles	6
Network number of phases	Single phase
[Us] rated supply voltage	24 V 48 V
Network type	DC
Communication interface	Ethernet/IP, integrated
Length	145.3 mm
Winding type	High speed of rotation and medium torque
Electrical connection	Printed circuit board connector
Holding brake	Without
Gear box type	Without
Nominal speed	5000 rpm at 24 V 7000 rpm at 48 V
Nominal torque	0.31 N.m

## Complementary

Transmission rate	125, 250, 500 kbauds
Mounting support	Flange
Motor flange size	57 mm
Number of motor stacks	1
Centring collar diameter	50 mm
Centring collar depth	1.6 mm
Number of mounting holes	4
Mounting holes diameter	5.2 mm
Circle diameter of the mounting holes	66.6 mm
Feedback type	Single turn encoder
Shaft end	Untapped
Second shaft	Without second shaft end
Shaft diameter	9 mm
Shaft length	20 mm
Supply voltage limits	18...55.2 V
Current consumption	11000 mA peak 7500 mA maximum continuous
Associated fuse rating	16 A
Commissioning interface	RS485 Modbus TCP (9.6, 19.2 and 38.4 kbauds)
Input/output type	4 signals (each be used as input or output)
Voltage state 0 guaranteed	-3...4.5 V
Voltage state 1 guaranteed	15...30 V
Discrete input current	10 MA at 24 V for safety input 2 mA at 24 V for 24 V signal interface
Discrete output voltage	23...25 V

Maximum switching current	100 MA per output 200 mA total
Protection type	Safe torque off Overload of output voltage Short circuit of the output voltage
Peak stall torque	0.45 N.m
Continuous stall torque	0.31 N.m
Speed feedback resolution	16384 points/turn
Accuracy error	+/- 0.05 °
Rotor inertia	0.095 kg.cm <sup>2</sup>
Maximum radial force Fr	89 N
Maximum axial force Fa	104 N (force pressure) 104 N (tensile force)
Service life in hours	20000 h bearing
Marking	CE
Type of cooling	Natural convection
Net weight	1.4 kg

## Environment

Standards	IEC 50347 IEC 50178 EN 61800-3:2001, second environment IEC 60072-1 EN 61800-3 : 2001-02 IEC 61800-3, Ed 2 IEC 61800-3
Product certifications	TÜV[RETURN]UL[RETURN]cUL
Ambient air temperature for operation	40...55 °C (with power derating of 2 % per °C) 0...40 °C (without derating)
Permissible ambient air temperature around the device	105 °C power amplifier 110 °C motor
Ambient air temperature for storage	-25...70 °C
Operating altitude	<= 1000 m without derating
Relative humidity	15...85 % without condensation
Vibration resistance	20 m/s <sup>2</sup> (f= 10...500 Hz) 10 cycles conforming to IEC 60068-2-6
Shock resistance	150 m/s <sup>2</sup> 1000 shocks conforming to IEC 60068-2-29
IP degree of protection	IP41 shaft bushing: conforming to IEC 60034-5 IP54 total except shaft bushing: conforming to IEC 60034-5

## Packing Units

Unit Type of Package 1	PCE
Number of Units in Package 1	1
Package 1 Height	8.0 cm
Package 1 Width	18.5 cm
Package 1 Length	35.5 cm
Package 1 Weight	1.7 kg

## Offer Sustainability

Sustainable offer status	Green Premium product
REACH Regulation	<a href="#">REACH Declaration</a>
EU RoHS Directive	Pro-active compliance (Product out of EU RoHS legal scope)
Mercury free	Yes
China RoHS Regulation	<a href="#">China RoHS Declaration</a>
RoHS exemption information	<a href="#">Yes</a>
Environmental Disclosure	<a href="#">Product Environmental Profile</a>
Circularity Profile	<a href="#">End Of Life Information</a>
WEEE	The product must be disposed on European Union markets following specific waste collection and never end up in rubbish bins

## Contractual warranty

---

Warranty	18 months
----------	-----------

---

Integrated Drive without Holding Brake

Dimensions

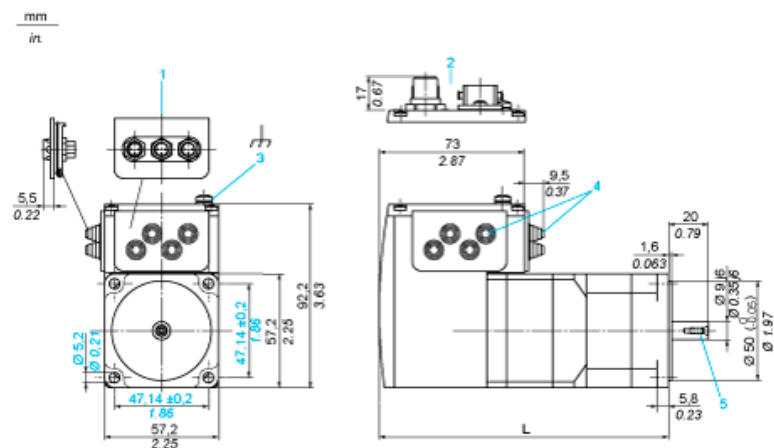

- 1 Accessories: I/O signal insert with industrial connectors
- 2 Option: industrial connectors
- 3 Earth (ground) terminal
- 4 Accessories: cable entries  $\varnothing = 3 \dots 9 \text{ mm}/0.12 \dots 0.35 \text{ in.}$
- 5 Centring hole DIN 332 - DS M3
- L 145.3 mm/5.72 in.

Connection Example with 4 I/O Signals



Torque Characteristics

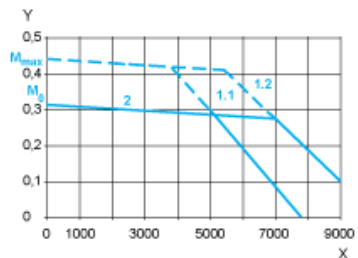

- X Speed of rotation in rpm
- Y Torque in Nm
- 1.1 Max. torque at 24 V
- 1.2 Max. torque at 48 V
- 2 Continuous torque