



Main

Range of product	Lexium integrated drive
Product or component type	Motion integrated drive
Device short name	ILS
Motor type	3-phase stepper motor
Number of motor poles	6
Network number of phases	Single phase
[Us] rated supply voltage	36 V 24 V
Network type	DC
Communication interface	CANopen DS301, integrated
Length	217.3 mm
Winding type	Medium speed of rotation and medium torque
Electrical connection	Industrial connector
Holding brake	With
Gear box type	Without
Nominal speed	100 rpm at 24 V 200 rpm at 36 V
Nominal torque	4 N.m
Holding torque	6 N.M holding brake 4 N.m

Complementary

Transmission rate	50, 100, 125, 250, 500, 800 and 1000 kbauds
Mounting support	Flange
Motor flange size	85 mm
Number of motor stacks	2
Centring collar diameter	60 mm
Centring collar depth	2 mm
Number of mounting holes	4
Mounting holes diameter	6.5 mm
Circle diameter of the mounting holes	99 mm
Feedback type	Index pulse
Shaft end	Untapped
Second shaft	Without second shaft end
Shaft diameter	12 mm
Shaft length	30 mm
Supply voltage limits	18...40 V
Current consumption	5000 mA maximum
Associated fuse rating	10 A
Input/output type	4 signals (each be used as input or output)
Voltage state 0 guaranteed	-3...4.5 V
Voltage state 1 guaranteed	15...30 V
Discrete input current	10 MA at 24 V on/STO_A for safety input 3 MA at 24 V on/STO_B for safety input 2 mA at 24 V for 24 V signal interface

The information provided in this documentation contains general descriptions and/or technical characteristics of the performance of the products contained herein. This documentation is not intended as a substitute for and is not to be used for determining suitability or reliability of these products for specific user applications. It is the duty of any such user or integrator to perform the appropriate and complete risk analysis, evaluation and testing of the products with respect to the relevant specific application or use thereof. Neither Schneider Electric Industries SAS nor any of its affiliates or subsidiaries shall be responsible or liable for misuse of the information contained herein.

Discrete output voltage	23...25 V
Maximum switching current	100 mA per output 200 mA total
Protection type	Safe torque off Short circuit of the output voltage Overload of output voltage
Peak stall torque	4 N.m
Continuous stall torque	4 N.m
Speed feedback resolution	20000 points/turn
Accuracy error	+/- 6 arc min
Rotor inertia	2.4 kg.cm ²
Maximum mechanical speed	1500 rpm
Maximum radial force Fr	100 N
Maximum axial force Fa	170 N (tensile force) 30 N (force pressure)
Service life in hours	20000 h bearing
Brake pull-in power	22 W
Brake release time	40 ms
Brake application time	20 ms
Marking	CE
Type of cooling	Natural convection
Net weight	5.4 kg



Environment

Standards	IEC 61800-3 IEC 60072-1 IEC 50178 IEC 61800-3, Ed 2 EN 61800-3 : 2001-02 IEC 50347 EN 61800-3:2001, second environment
Product certifications	TÜV[RETURN]cUL[RETURN]UL
Ambient air temperature for operation	50...65 °C (with power derating of 2 % per °C) 0...50 °C (without derating)
Permissible ambient air temperature around the device	105 °C power amplifier 110 °C motor
Ambient air temperature for storage	-25...70 °C
Operating altitude	<= 1000 m without derating
Relative humidity	15...85 % without condensation
Vibration resistance	20 m/s ² (f= 10...500 Hz) 10 cycles conforming to IEC 60068-2-6
Shock resistance	150 m/s ² 1000 shocks conforming to IEC 60068-2-29
IP degree of protection	IP41 shaft bushing: conforming to IEC 60034-5 IP54 total except shaft bushing: conforming to IEC 60034-5

Packing Units

Unit Type of Package 1	PCE
Number of Units in Package 1	1
Package 1 Height	10.5 cm
Package 1 Width	19.0 cm
Package 1 Length	39.0 cm
Package 1 Weight	4.4 kg

Offer Sustainability

Sustainable offer status	Green Premium product
REACH Regulation	 REACH Declaration
EU RoHS Directive	Pro-active compliance (Product out of EU RoHS legal scope)
Mercury free	Yes
China RoHS Regulation	 China RoHS Declaration

RoHS exemption information	Yes
Environmental Disclosure	Product Environmental Profile
Circularity Profile	End Of Life Information
WEEE	The product must be disposed on European Union markets following specific waste collection and never end up in rubbish bins
Contractual warranty	
Warranty	18 months

Integrated Drive with Holding Brake

Dimensions

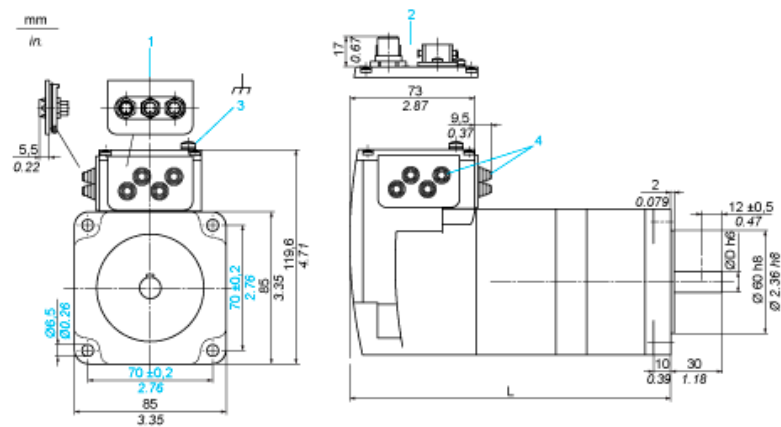

- 1 Accessories: I/O signal insert with industrial connectors
- 2 Option: industrial connectors
- 3 Earth (ground) terminal
- 4 Accessories: cable entries $\varnothing = 3 \dots 9 \text{ mm}/0.12 \dots 0.35 \text{ in.}$
- L 217.3 mm/8.55 in.
- D 12 mm/0.47 in.

Connection Example with 4 I/O Signals



Torque Characteristics

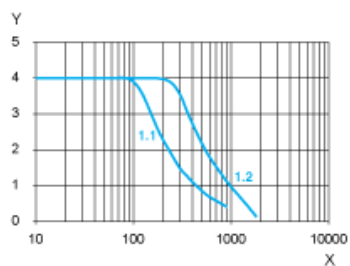

X Speed of rotation in rpm

Y Torque in Nm

1.1 Max. torque at 24 V

1.2 Max. torque at 36 V