

Main

| | |
|---------------------------|-------------|
| Range compatibility | PacDrive 3 |
| Device short name | SH3.....P |
| Product or component type | Servo motor |

Complementary

| | |
|---------------------------|--|
| Maximum mechanical speed | 6000 rpm |
| [Us] rated supply voltage | 115...480 V |
| Network number of phases | Three phase |
| Continuous stall current | 4.8 A |
| Continuous stall torque | 5.8 N.m at 115...480 V three phase |
| Continuous power | 1930 W |
| Peak stall torque | 18.3 N.m at 115...480 V three phase |
| Nominal output power | 1090 W at 230 V single phase 1930 W at 400 V three phase 1930 W at 480 V three phase |
| Nominal torque | 5.2 N.M at 230 V single phase 4.6 N.M at 400 V three phase 4.4 N.m at 480 V three phase |
| Nominal speed | 2000 rpm at 230 V single phase 4000 rpm at 400 V three phase 4800 rpm at 480 V three phase |
| Maximum current Irms | 17.1 A |
| Shaft end | Parallel key |
| Shaft diameter | 19 mm |
| Shaft length | 40 mm |
| Key width | 6 mm |
| IP degree of protection | IP65 motor: conforming to EN/IEC 60034-5 IP65 shaft bushing: conforming to EN/IEC 60034-5 |
| Encoder type | Absolute multiturn Hiperface DSL |
| Speed feedback resolution | 262144 points/turn x 4096 turns |
| Holding brake | Without |
| Mounting support | International standard flange |
| Motor flange size | 100 mm |
| Electrical connection | Rotatable right angled connector |
| Torque constant | 1.21 N.m/A at 120 °C |
| Back emf constant | 77 V/krpm at 20 °C |
| Number of motor poles | 4 |
| Rotor inertia | 2.31 kg.cm ² |
| Stator resistance | 2.4 Ohm |
| Stator inductance | 13.5 mH |

The information provided in this documentation contains general descriptions and/or technical characteristics of the performance of the products contained herein. This documentation is not intended as a substitute for and is not to be used for determining suitability or reliability of these products for specific user applications. It is the duty of any such user or integrator to perform the appropriate and complete risk analysis, evaluation and testing of the products with respect to the relevant specific application or use thereof. Neither Schneider Electric Industries SAS nor any of its affiliates or subsidiaries shall be responsible or liable for misuse of the information contained herein.

| | |
|---------------------------------------|--|
| Maximum radial force Fr | 2960 N at 2000 rpm 2580 N at 3000 rpm 3730 N at 1000 rpm |
| Maximum axial force Fa | 740 N |
| Type of cooling | Natural convection |
| Length | 204.5 mm |
| Centring collar diameter | 95 mm |
| Centring collar depth | 3.5 mm |
| Number of mounting holes | 4 |
| Mounting holes diameter | 9.0 mm |
| Circle diameter of the mounting holes | 115 mm |
| Net weight | 5.9 kg |

Packing Units

| | |
|------------------------------|---------|
| Unit Type of Package 1 | PCE |
| Number of Units in Package 1 | 1 |
| Package 1 Height | 21.0 cm |
| Package 1 Width | 18.0 cm |
| Package 1 Length | 35.6 cm |
| Package 1 Weight | 6.6 kg |

Offer Sustainability

| | |
|----------------------------|---|
| Sustainable offer status | Green Premium product |
| REACH Regulation |  REACH Declaration |
| EU RoHS Directive | Pro-active compliance (Product out of EU RoHS legal scope) |
| Mercury free | Yes |
| China RoHS Regulation |  China RoHS Declaration |
| RoHS exemption information |  Yes |
| Environmental Disclosure |  Product Environmental Profile |
| Circularity Profile | No need of specific recycling operations |
| WEEE | The product must be disposed on European Union markets following specific waste collection and never end up in rubbish bins |
| PVC free | Yes |

Dimensions

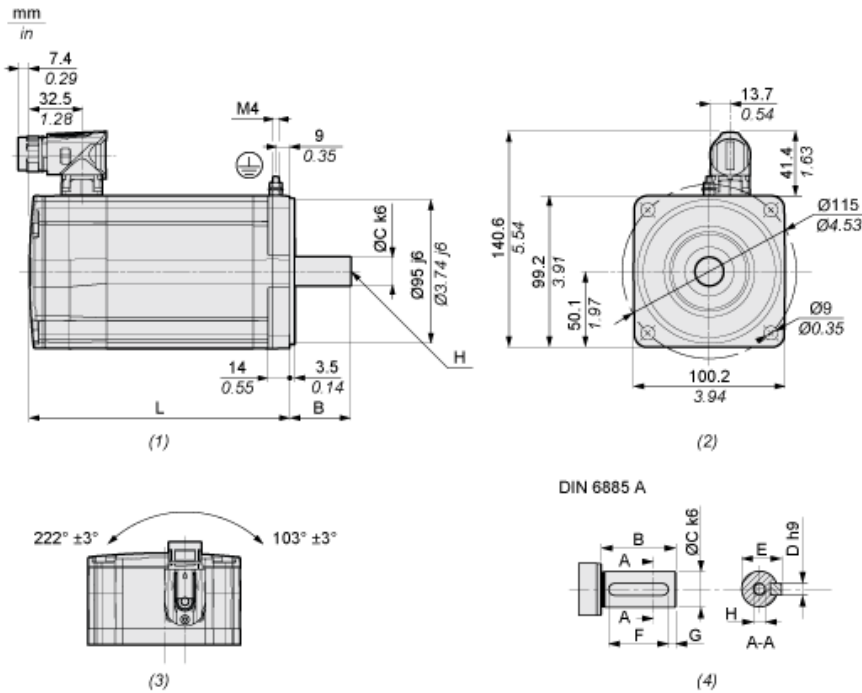

- (1) : Side view
- (2) : Mounting
- (3) : Rotating area
- (4) : Feather key

| Characteristic | | Unit | Value |
|----------------|------------------------------------|---------|------------------|
| L | Length without holding brake | mm (in) | 204.5 (8.05) |
| B | Shaft length | mm (in) | 40 (1.57) |
| C | Shaft diameter | mm (in) | 19 (0.75) |
| D | Width of parallel key | mm (in) | 6 (0.24) |
| E | Shaft width with parallel key | mm (in) | 21.5 (0.85) |
| F | Length of parallel key | mm (in) | 30 (1.18) |
| G | Distance parallel key to shaft end | mm (in) | 5 (0.2) |
| H | Female thread of shaft | | DIN 332-D M6 |
| | Parallel key | | DIN 6885-A6x6x30 |