



Main

Range of product	Preventa Safety automation
Product or component type	Safe input expansion module
Device short name	XPSMCM
Electrical connection	Screw terminal
[Us] rated supply voltage	24 V - 20...20 % DC
Number of inputs	4.0 analog
Function of module	Analogue input current for analog input Analogue input voltage for analog input current

Complementary

Maximum power consumption in W	3 W
Power dissipation in W	3 W
Integrated connection type	Backplane expansion bus
Number of terminal blocks	4
Connections - terminals	2 captive screw clamp terminals, removable terminal block 1 captive screw clamp terminals, removable terminal block
Voltage state 0 guaranteed	0...10 V for analog input 0...10 V for analog input voltage 0...10 V for analogue input 0...10 V for analogue input circuit 0...10 V for analogue input signals 0...10 V for temperature sensor
Current state 0 guaranteed	0...20 mA (analog input) 0...20 mA (analog input current) 0...20 mA (analogue input) 0...20 mA (analogue input circuit) 0...20 mA (analogue input signals) 0...20 mA (temperature sensor)
Safety level	Can reach category 4 conforming to ISO 13849-1 Can reach PL = e conforming to ISO 13849-1 Can reach SIL 3 conforming to IEC 61508 SILCL 3 conforming to IEC 62061
Quality labels	CE
Discrete input voltage	24 V DC
Local signalling	1 LED green with PWR marking for power ON 1 LED green with RUN marking for RUN (status) 1 LED red with E IN marking for internal error 1 LED red with E EX marking for external error 2 LEDs orange with ADDR marking for node address 4 LEDs green/red with IN marking for input status
Cable cross section	0.2...1.5 Mm ² - AWG 24...AWG 16 flexible cablewithout cable end 0.2...2.5 Mm ² - AWG 24...AWG 14 flexible cablewithout cable end 0.25...1 Mm ² - AWG 23...AWG 18 flexible cablewith cable end, without bezel 0.25...2.5 Mm ² - AWG 23...AWG 14 flexible cablewith cable end, with bezel 0.25...2.5 Mm ² - AWG 23...AWG 14 flexible cablewith cable end, without bezel 0.5...1.5 Mm ² - AWG 20...AWG 16 flexible cablewith cable end, with double bezel 0.2...1 Mm ² - AWG 24...AWG 18 solid cablewithout cable end 0.2...2.5 mm ² - AWG 24...AWG 14 solid cablewithout cable end
Mounting support	Omega 35 mm DIN rail conforming to EN 50022
Depth	114.5 mm
Height	99 mm
Width	22.5 mm
Net weight	0.164 kg

Environment

Standards	IEC 62061 IEC 61508 ISO 13849-1 IEC 61800-5-1
Product certifications	RCM[RETURN]cULus[RETURN]TÜV
IP degree of protection	IP20 (enclosure)
Ambient air temperature for operation	-10...55 °C
Ambient air temperature for storage	-20...85 °C
Relative humidity	10...95 %
Pollution degree	2
[Uimp] rated impulse withstand voltage	4 kV conforming to IEC 61800-5-1
Safety reliability data	PFHd = 1.53E-8 1/h DC > 99 % MTTFd = 106 years high
Insulation	250 V AC between power supply and housing conforming to IEC 61800-5-1
Overvoltage category	II
Electromagnetic compatibility	Electrostatic discharge immunity test - test level: 6 kV (on contact) conforming to IEC 61000-4-2 Electrostatic discharge immunity test - test level: 20 kV (on air) conforming to IEC 61000-4-2 Susceptibility to electromagnetic fields - test level: 10 V/m (80...1000 MHz) conforming to IEC 61000-4-3 Susceptibility to electromagnetic fields - test level: 30 V/m (1.4 GHz...2 GHz) conforming to IEC 61000-4-3
Vibration resistance	+/-0.35 mm (f= 10...55 Hz) conforming to IEC 61496-1
Shock resistance	10 gn (duration = 16 ms) for 1000 shocks on each axis conforming to IEC 61496-1
Service life	20 year(s)

Packing Units

Unit Type of Package 1	PCE
Number of Units in Package 1	1
Package 1 Height	4.6 cm
Package 1 Width	12.7 cm
Package 1 Length	16.2 cm
Package 1 Weight	259.0 g
Unit Type of Package 2	S03
Number of Units in Package 2	26
Package 2 Height	30.0 cm
Package 2 Width	30.0 cm
Package 2 Length	40.0 cm
Package 2 Weight	7.327 kg

Offer Sustainability

REACH Regulation	REACH Declaration
REACH free of SVHC	Yes
EU RoHS Directive	Pro-active compliance (Product out of EU RoHS legal scope)
Mercury free	Yes
China RoHS Regulation	China RoHS Declaration
RoHS exemption information	Yes
WEEE	The product must be disposed on European Union markets following specific waste collection and never end up in rubbish bins

Dimensions

Screw Terminal

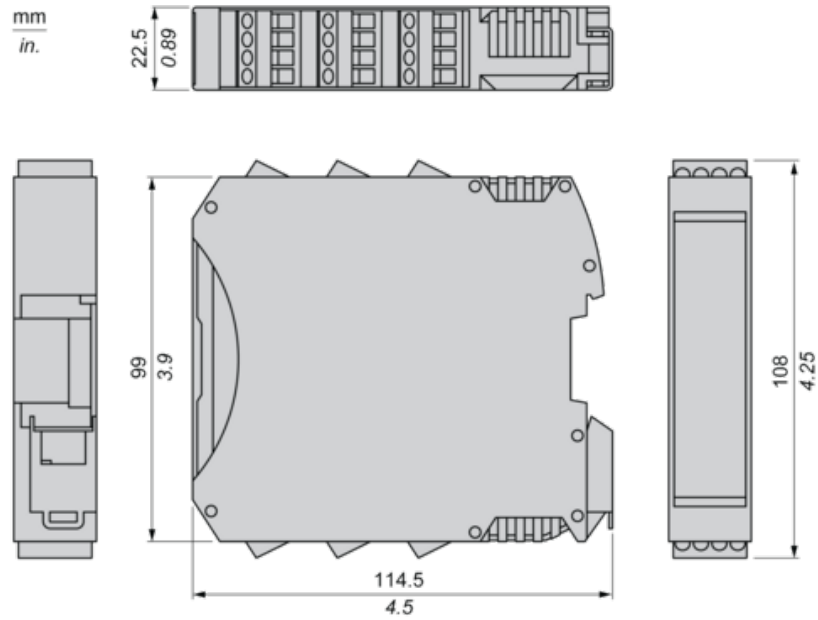

Mounting Safety Controller CPU with Module(s)

Mount BackPlane Connector on Rail

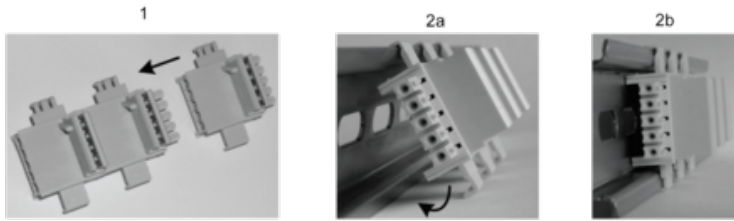

- 1 : Connect as much Backplane Connector as module to be install.
2 : Fix the connectors to the rail (Top first).

Mount Safety Controller CPU with Other Module(s)

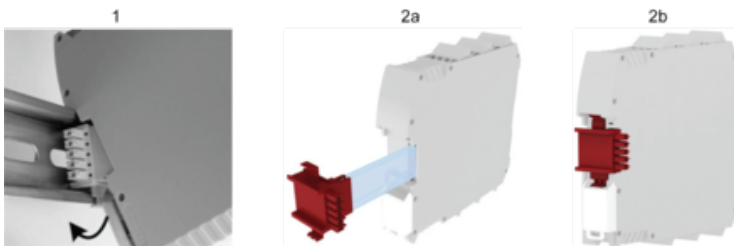

- 1 : Mount controller CPU and modules on rail.
2 : Make sure that the controller CPU or the module(s) are plugged on the BackPlane connector.

Wiring

Terminal Designation

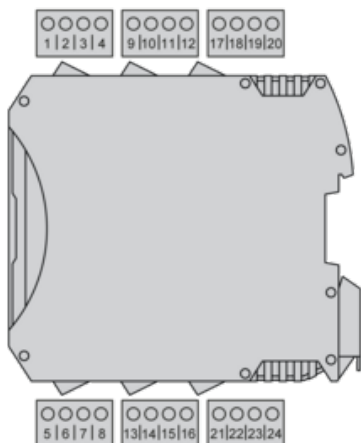

Terminal	Signal	Description
1	24 VDC	24 Vdc power supply
2	NODE_ADDR0	Node selection
3	NODE_ADDR0	
4	0 VDC	0 Vdc power supply
9	24VDC_S1	Sensor 1 connections
10	IN_S1	
NEG_S1		
11	OUT_S1	
POS_S1		
12	0 VDC_S1	
13	24VDC_S3	Sensor 3 connections
14	IN_S3	
NEG_S3		
15	OUT_S3	
POS_S3		
16	0 VDC_S3	
17	24VDC_S2	Sensor 2 connections
18	IN_S2	
NEG_S2		
19	OUT_S2	
POS_S2		
20	0 VDC_S2	
21	24VDC_S4	Sensor 4 connections
22	IN_S4	
NEG_S4		
23	OUT_S4	
POS_S4		

Terminal	Signal	Description
24	0 VDC_S4	

Wiring Example

2 Wires Current Sensor

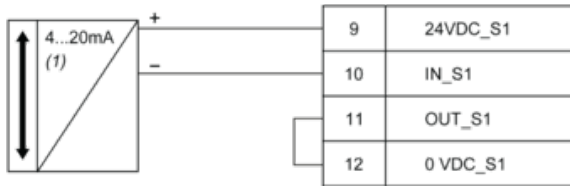

(1) : Sensor

3 Wires Current Sensor

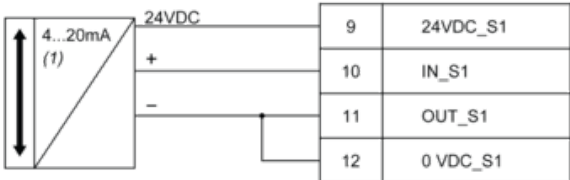

(1) : Sensor

4 Wires Current Sensor

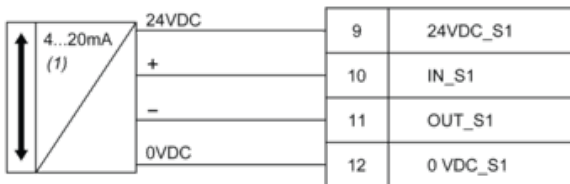

(1) : Sensor

3 Wires Voltage Sensor

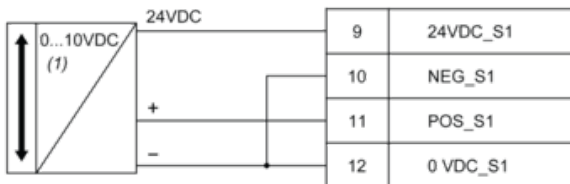

(1) : Sensor